

Well Construction

Cementing Technologies

ULTRALATCH™ Subsurface Release Plug System

The ULTRALATCH™ Subsurface Release Plug System prevents contamination of the cement slurry pumped through the casing and drill pipe for increased cement and well integrity.

The ULTRALATCH™ system features a mechanical latch mechanism that acts as a backup to the float equipment for increased wellbore integrity. Expro's Disposable Plug Running Tool (dPRT) allows the plugs to be easily installed on the casing or liner hanger running tool without the maintenance and logistics costs associated with rental running tools.

Features and benefits

- Latch-down noses secure the system into landing collar and float equipment for reliable bump, backpressure capability, and improved drill-out.
- Manufactured with mostly composite material to allow for optimal drill-out with PDC bit designs for increased time and cost savings.
- Emergency plug release feature on dPRT allows for continued displacement of cement and wellbore fluids during cementing operations.
- dPRT allows plug sets to be made-up to all liner and casing hanger running tools for improved operational efficiency and flexibility.
- Pressure equalizer in dPRT ensures plugs are pressure balanced to reduce the risk of premature launch.
- Optional ball catcher baffle retains diverter closing and liner setting balls for improved drill-out operations.

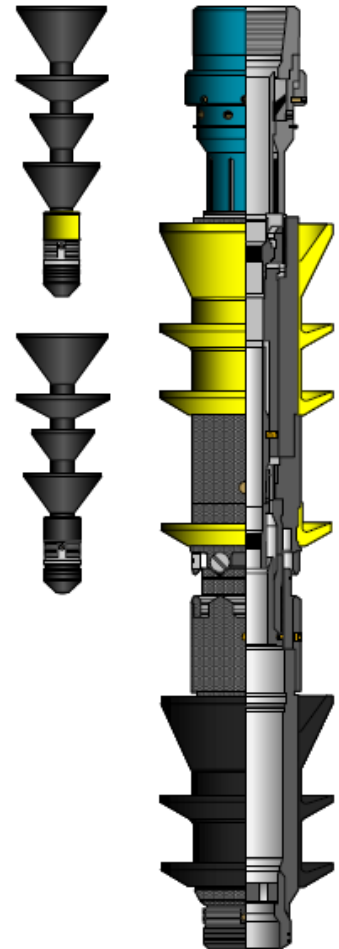



Well Construction

Cementing Technologies

ULTRALATCH™ Subsurface Release Plug System

Specifications							
Configuration	Liner / casing size	Min. plug I.D. (in.)	Top dart rigid O.D. (in.)	Bottom dart rigid O.D. (in.)	Bump pressure (psi)	dPRT ¹ max. O.D. (in.)	dPRT min. I.D. (in.)
Single	7" to 8-5/8" (Aluminum core material)	2.265	2.350	N/A	8,500	5.500	2.375
Single	9-5/8" to 22" (Composite core material)	2.265 / 2.445	2.350 / 2.500	N/A	6,500	6.395	2.620
Dual	7" to 8-5/8" (Aluminum core material)	2.187	2.350	2.240	8,500	5.500	2.375
Dual	9-5/8" to 22" (Composite core material)	2.313	2.500	2.370	6,500	6.395	2.620

1. Standard dPRT connection is 4-1/2" LTC Box. Maximum flow rate prior to launching plugs (for all sizes) is 18 bbl/min for 24 hrs